

BOLDLY  
MOVING  
INTO THE  
FUTURE

Condor

GUNBOAT 68

[www.gunboat.com](http://www.gunboat.com)

GRAND LARGE YACHTING GROUP

GUNBOAT 68

## Welcome Aboard

Whether you plan to sail your Gunboat over the horizon on a global cruise or take line honors at regattas, the Gunboat 68 will get you there in speed, comfort and style. Owning a Gunboat is more than owning a boat, its choosing a lifestyle.

Play the video 





GUNBOAT 68

LUXURY WITHOUT  
COMPROMISE

The benchmark in luxury, performance catamarans is raised once again by Gunboat, with refined aesthetics, comfort, and performance engineering.

GUNBOAT 68

## Fast, advanced, and elegantly designed

The Gunboat 68 is the culmination of development within the fleet since the first Gunboat launched in 2002. Incorporating the best of what has come before with experienced boatbuilding and valuable industry partnerships, the Gunboat 68 is a step-change in the evolution of the brand.





## Design Brief

The Design Parameters were driven by the heritage and trailblazing nature of Gunboat – to make no compromise on performance, luxury, equipment, and comfort on a platform conceived for safe, fast world-cruising. The stunning exterior lines exude speed. The luxurious interior delivers true comfort and refined style; Clean, modern, and purposeful design, at the same time with real luxury embodied in her every aspect. Systems were engineered to be accessible and require minimal maintenance. Semi-customizable layouts and well-thought-out options deliver versatility and personalize each Gunboat 68 to reflect the individuality of her owner. Ultimately, evolutions in the new design merely enhance the core Gunboat DNA: practical, lightweight, high-performance, and ready to sail the globe.





GUNBOAT 68



## The dream team

**The world's foremost multihull naval architects and leaders in the interior and exterior yacht design industry came together to move the needle of the high-performance cruising catamaran market yet again.**

This newest Gunboat model evolved through a close collaborative loop between Gunboat, VPLP, Patrick Le Quément and Christophe Chedal Anglay. Together, interior and exterior designers achieved a closely linked ergonomic and practical design; capturing the essence of Gunboat, maintaining the semi-utilitarian balance focused on performance and function, while designing luxury and aesthetics down to the detail. Further, this new era of Gunboat benefits from expanded professional networks, tapping into the French multihull sector and aviation industries. Beautiful and functional, luxurious and performance-driven, and a true manifestation of the iconic brand name into the next generation.



### NAVAL ARCHITECTS

VPLP design has had unrivaled success in the cruising, racing and superyacht multihull market. They represent the pinnacle of performance multihull design, and VPLP designed multihulls hold incredible world records such as the 24-hour Absolute Distance record (Banque Populaire V - 908 nm/37.8 kts), 24-hour Singlehanded Distance record (Macif - 784 nm/32.67 kts), Jules Verne Trophy 2017 (IDEC Sport - 40d 23hr), and Round the World Singlehanded 2017 (Macif, 42d 16hr)

### DESIGN

Patrick le Quément (formerly the head designer at Ford and Renault) and Christophe Chedal Anglay (boasting a design portfolio of elegant high performance catamarans) worked together to propel the exterior design of the Gunboat 68 into a new dimension. Chedal Anglay also lead the efforts on interior design, realizing a vision for a bespoke interior that is both comfortable and classy.



GUNBOAT 68



*"In design, there is this rule that one searches for balance. With the Gunboat 68 we sought the perfect imbalance – the notion of movement and speed. The proportions make the boat look right, like it is positioned moving forward in the sea and totally adequate for its purpose. There are no straight lines – everything is designed with taut curves as in nature."*

-Patrick le Quément





STUNNING  
HEAD-TURNER,  
BLUE-WATER,  
PERFORMANCE  
CRUISER.

GUNBOAT 68

## Exterior Design

**The lightweight, all-carbon composite construction of the Gunboat 68 is the foundation of this robust platform, purpose-built for the wide variety of conditions encountered when offshore sailing.**

Design features include less rocker for reduced pitching, long, high-aspect straight daggerboards, and wave-piercing bows. Retractable rudders open up global cruising grounds to adventure where other 68 footers could only dream to go, from exploring skinny-water destinations to entering anchorages and marinas otherwise off-limits. Increased beam yields more righting moment for higher safety margins and increased performance, while the mast located further aft enables an optimized sailplan. All design decisions were made with performance, aesthetics, and utmost safety in mind for extended, blue-water cruising.





GUNBOAT 68

The cabin house design offers maximum real estate for solar panels and a built-in recessed hand grip/rail underneath, while visually it is beautifully streamlined with the wraparound windows.



GUNBOAT 68

Long topside windows amplify the sleek design and deliver abundant natural lighting in the hull cabins.



GUNBOAT 68



The traveler is mounted on the aft beam in conjunction with the mast positioned further aft yields a balanced, modern sail profile - with the added bonus of a customizable entertainment area in the same aft structure.



GUNBOAT 66

LIFE IS TOO SHORT  
TO SAIL A SLOW BOAT







## Safety is paramount

From design and structure to systems and equipment, the Gunboat 68 proactively incorporates safety measures. Increased beam yields more righting moment for higher safety margins. Crash bows and two watertight bulkheads behind them ensure uncompromised airtight spaces (offering protection in the unlikely event of collision). Structurally, dedicated “flotation” areas are built into the stern roof and bridgedeck. Closed cell foam is highly buoyant. Add to that, the Gunboat 68 includes many systems redundancies as well as the anticapsizing systems, an integrated life raft storage built into the bridgedeck, and man overboard modules that can easily be triggered. The forward and aft cockpit areas are contained spaces offering greater safety whether cruising with family, racing with pros, or on an offshore, overnight passage. As final conservative measures, the Gunboat 68 was designed with charter safety regulations in mind, and our thorough commissioning and sea trials checklist facilitates trust in taking ownership of a new Gunboat.



GUNBOAT 68



Gunboat 68 Condor cruising the Med;  
Porquerolles Island in Hyères, France







GUNBOAT

STRONGER,  
LIGHTER,  
FASTER







## The Build

**The steadfast ambition that sparked Gunboat - applying proven, Grand Prix race boat building and sailing performance technology to what is at its core, a highly-capable, world cruising boat -realized by an experienced, dedicated team working in top facilities.**

- Engineering by VPLP, the “fastest naval architects in the world”, and uniquely the foremost offshore racing as well as cruising multihull designers;
- Built by Gunboat in La Grande-Motte, France, operating with the experience and mentality of a raceboat campaign, focused on strength and weight;
- Top-quality materials that are best suited for every application of the build: Epoxy resin, carbon, corecell foam, and nomex honeycomb to name a few;
- Processes that match each given material and aspect of the build - such as thermoforming the core; vacuum infusion for the hull, deck and roof; and full prepreg for internal structural components, including the interior bulkheads;
- Assembly in our state-of-the-art, temperature controlled factory, using the best adhesives and resins from the top suppliers; maintaining a clean, dust-free yard with European safety and environmental standards.



## The Build

**Process, quality,  
and rigor**

Technology, experience, collaboration and craftsmanship by a passionate boatbuilding team... Each yacht is delivered with pride and confidence - on weight, following a rigorous commissioning process.





## Interior Design

The new Gunboat 68 sets the standard in catamaran interiors, conceived to incorporate the range of owners' preferences and intended uses, and available in four-, five-, and six-cabin layouts.

### AN INNER SENSE OF LIGHT

The disciplined focus on weight and performance design continues throughout the interior, combining plush design and lightweight construction. The versatile bridgedeck layout features the convenience of some interior elements that are removable for weight optimization and racing.



### LUXURY WITHOUT COMPROMISE

The forms of the interior reflect the iconic pure curves of the hull structure and the unique spirit of Gunboat. The choice of quality materials optimizes the feel of light and space, creating clean spaces with ergonomics and practicality at the forefront. Space was maximized for usable storage and comfortable headroom. Customizations offer plenty of space for your personality too - each yacht will be truly unique.

### OPTIMIZED ACCOMMODATIONS

"We'll have done a good job if nobody notices." Christophe Chedal Anglay  
Recessed lighting, air conditioning that surrounds the bed in slow-moving cool air, upholstery panels that absorb sound. Optimized sightlines and natural light, an ocean view from every cabin. Comforts you will feel and organically enjoy were thoughtfully designed, to the detail.





## Aft Cockpit

Spacious and plush, the aft cockpit is the ideal atmosphere for relaxing, dining and entertaining. Stretch out on generous bench seating, designed with ample storage space beneath for gear and supplies. Customize the entertainment area with a combination of outdoor “galley” options built into the aft beam - BBQ, drinks fridge, ice maker or sink - for extended outdoor lounging sessions.



## Salon

The open bridgedeck salon offers magnificent 360-degree visibility and air flow. Balance the indoor/outdoor feel with the large doors and windows to the forward and aft cockpits, as well as the retractable moonroof overtop of the helm station - and enclose them all for climate control. The salon features the galley located to port and a countertop island. To starboard in the dining area, the convertible table can open up to accommodate extra dinner guests or lower to create a comfortable daybed.











## Central helm

A breeze to sail, even shorthanded. Access everything from “mission control”, with navigational displays directly in front of the carbon fiber helm and the forward sail handling cockpit just two steps further. One step to the right, reach the navigation station for engine controls and touchscreen management of the systems on board. Maintain control literally without losing sight of anything via windows, double doors and an overhead retractable moonroof designed for excellent sight lines to the sails and working cockpit. Visibility and proximity to crew and guests also facilitates clear, easy communication, making sailing even safer and more enjoyable.

A true connection between helmsman and boat, the newly designed Gunboat 68 steering system delivers an exceptional, well-balanced feel and can be adjusted to give the owner the response level they want. Add to that the optional tillers for back-of-the-boat steering to further optimize sailing-to-the-fullest in any conditions.



## Galley

Superb views and fresh breezes flow through the bridgedeck galley. The galley is equipped with wraparound countertops with an integrated gas range/oven, and large cabinet and cupboard storage beneath. The central galley island houses double-door refrigerator/freezer units. No matter where you are in the world - as part of the sailing action, while at sea or at a beautiful private anchorage - food and the salon-galley bring people together.





## Accommodations

Stretch out in the four spacious and contemporary, luxury state rooms with ensuite heads that come standard on every Gunboat 68. These bright and airy staterooms each have queen-sized natural light and excellent views of the harbor from the long topside windows, which may also be covered for privacy.

### **MASTER AMIDSHIPS CABINS**

The two amidships berths have 'island' queen sized beds with stairs up either side and integrated storage. Very private area, gigantic shower, walk-in wardrobe/closet.





Master cabin featuring additional storage between the bed and en-suite head, and a walk-in closet.

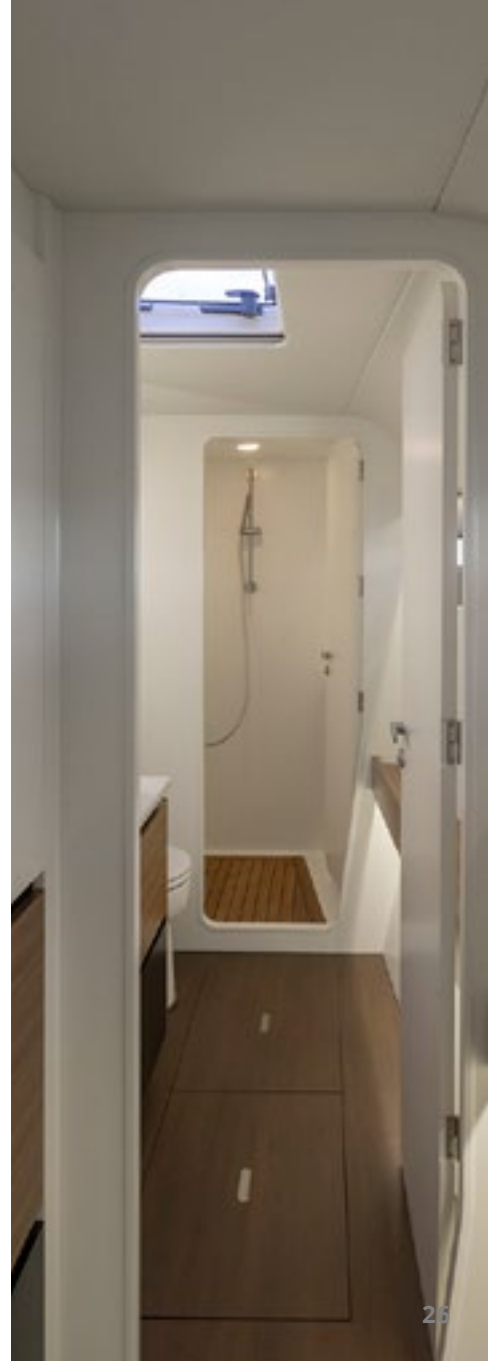
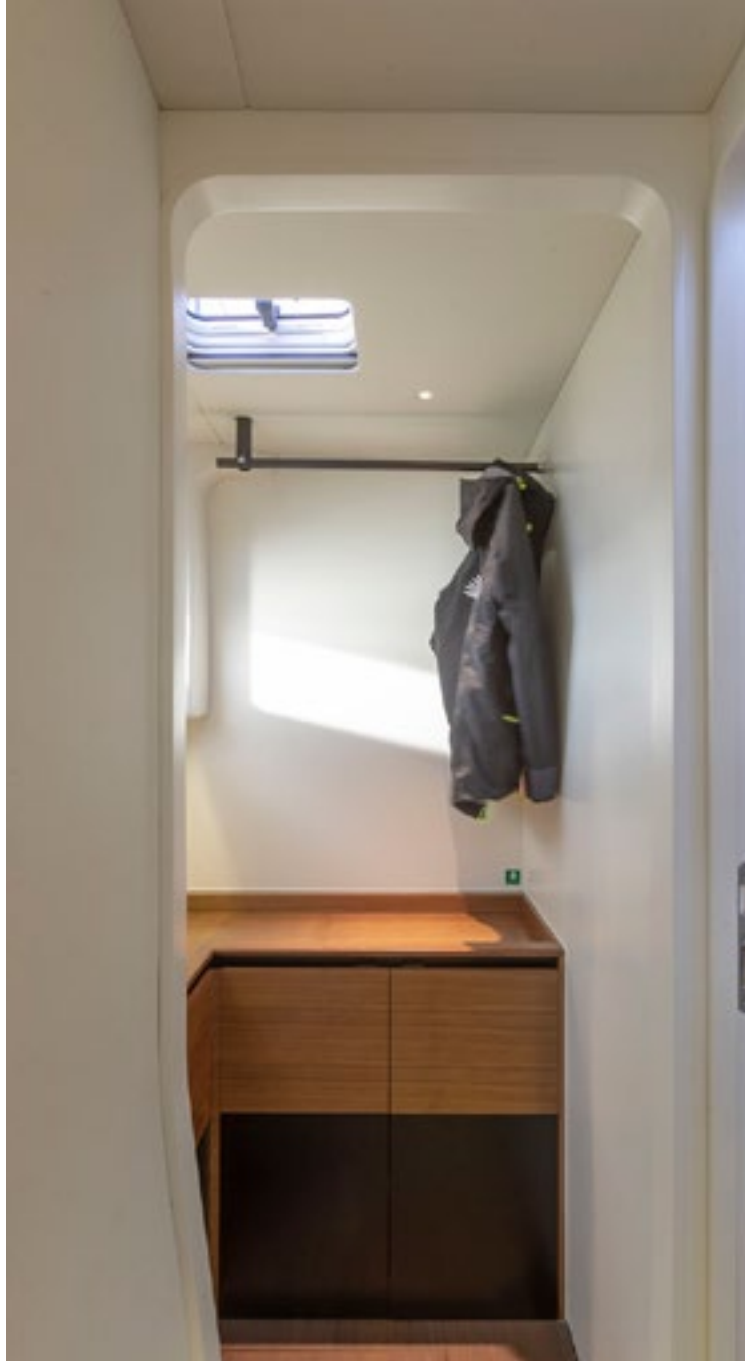



## Aft Guest cabins

Bright, spacious and airy with 180 degree water views, natural light pours into the two aft cabins which feature queen sized beds, ample headroom, and smart storage.



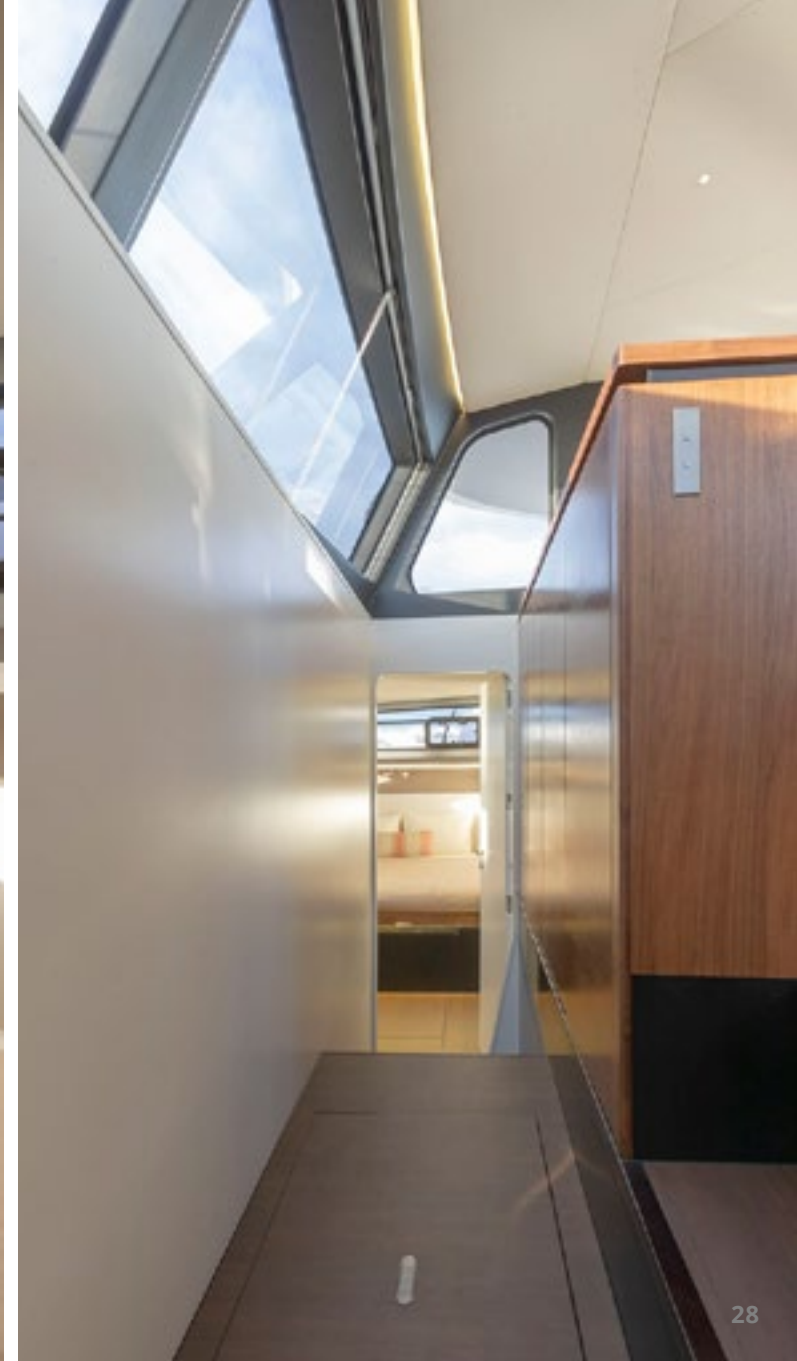

## Ensuite head

On the standard layout options of 4-6 cabins, ensuite heads for each cabin are each equipped with a toilet, sink, vanity and mirror and an adjoining shower – or opt to vary this use of space with the additional layout options that can be selected for the five- or six- cabin version.





GUNBOAT 68



Four cabin



Five cabin



Six cabin



## Bridgedeck

The highly versatile interior features demountable furniture in the salon and aft cockpit to give owners several interior configurations. Move, link and lock it in place to modify the bridgedeck interior layout quickly and easily for cruise, race, cocktail party, dinner or lounge modes.

Head out to the race course with a fully stripped out interior in "race mode" and come back to the dock and easily install the "cocktail party" setup for post-race festivities.

Seek ultimate relaxation with multiple daybed options in "lounge mode".

Truly create your ideal setting for relaxation, entertaining, and sailing.



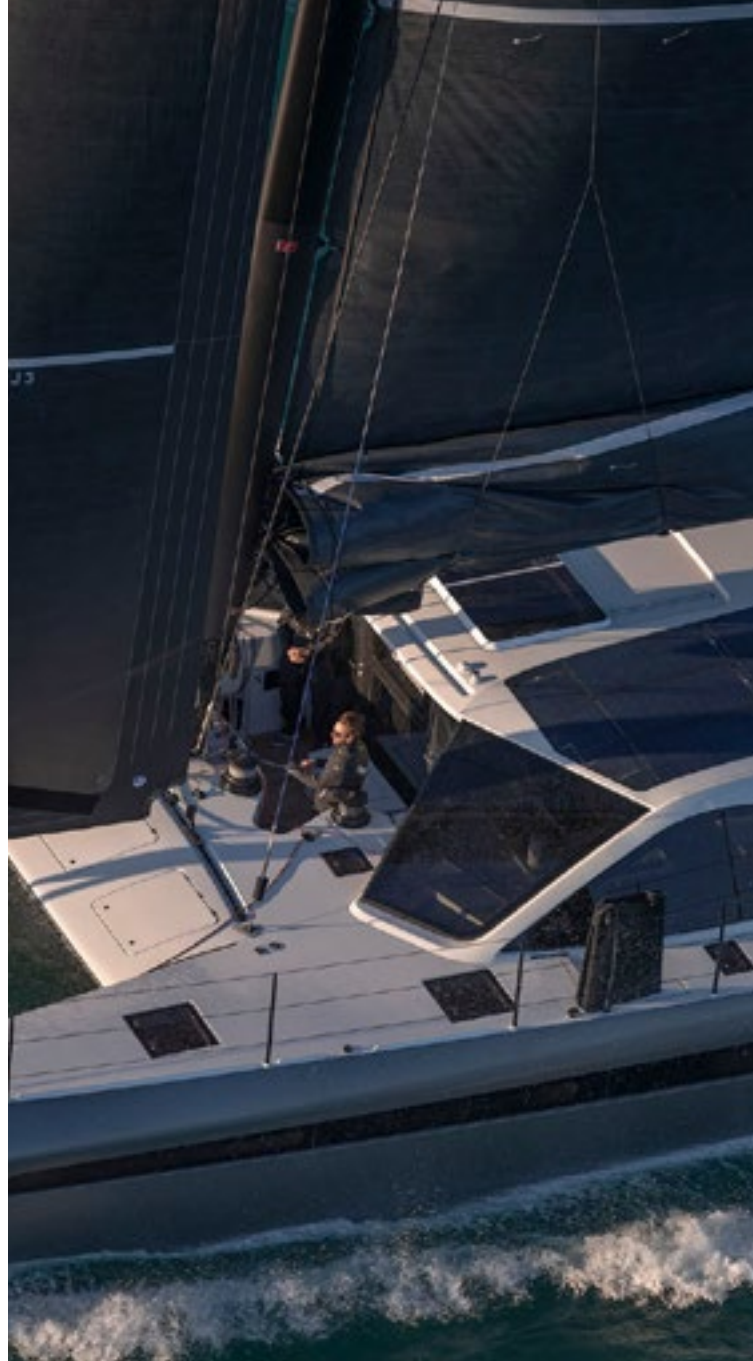

## Sail Handling

Sail a performance cat at speed with comfort and ease. All sails are centrally controlled from the spacious forward cockpit, with a streamlined and ergonomically engineered deck gear layout. Well-equipped, the trickle-down from the great ocean races informed the selection of deck gear, running rigging, and a rope package that are proven to be lightweight and strong for longevity. Winches are placed four abreast in the forward cockpit and two on the aft beam. In cruise-mode, all lines can be lead forward just one step away from the helmsman and with crew in close proximity. For racing, headsails can be trimmed from the aft beam winches. From the forward cockpit, wide steps lead up to the side decks for quick, safe access to sail changes. Additionally push button technology is available with an optional hydraulics package. Deck gear and sail handling were designed purposefully identifying the best locations for communication and to view sail trim.



## Rig and Sail Plans

Cruise in comfort with your family or trim for speed in race mode – with plans conceptualized specifically for your sailing preferences. Race-industry technology is applied to this platform with an intentional focus on remaining simple, strong and reliable. The 25-meter Standard Mast offers exhilarating performance, and the 29-meter Regatta Mast turbos performance to rival the fastest boats afloat. Choose the sail plan and package that best matches your need... for speed!

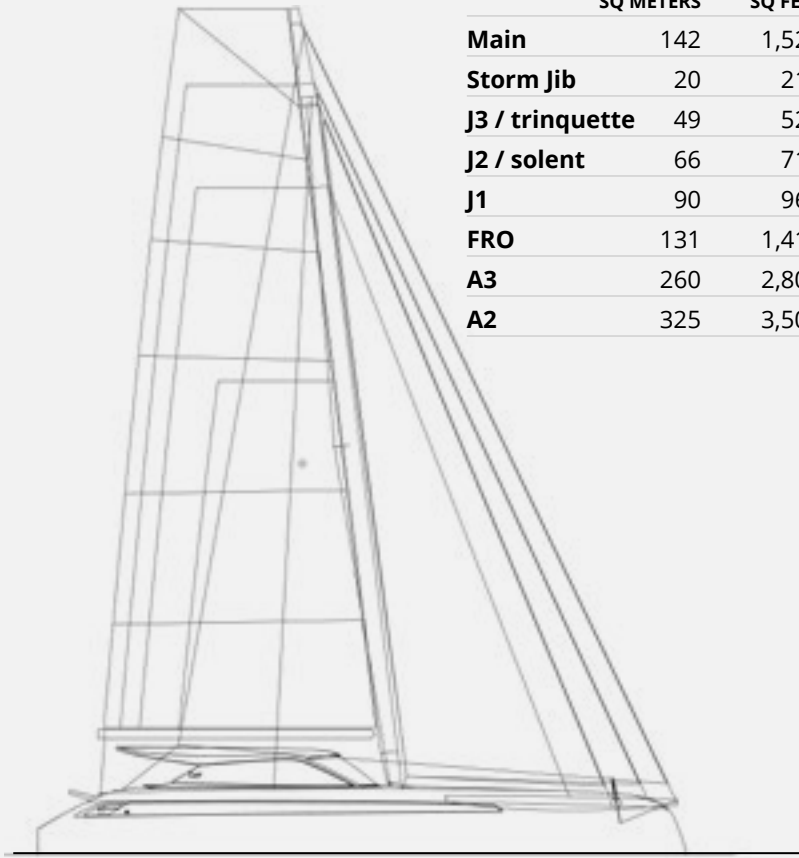

**CRUISING MAST**  
25M

	SQ METERS	SQ FEET
<b>Main</b>	142	1,528
<b>Storm Jib</b>	20	214
<b>J3 / trinquette</b>	49	527
<b>J2 / solent</b>	66	710
<b>J1</b>	90	969
<b>FRO</b>	131	1,410
<b>A3</b>	260	2,800
<b>A2</b>	325	3,500

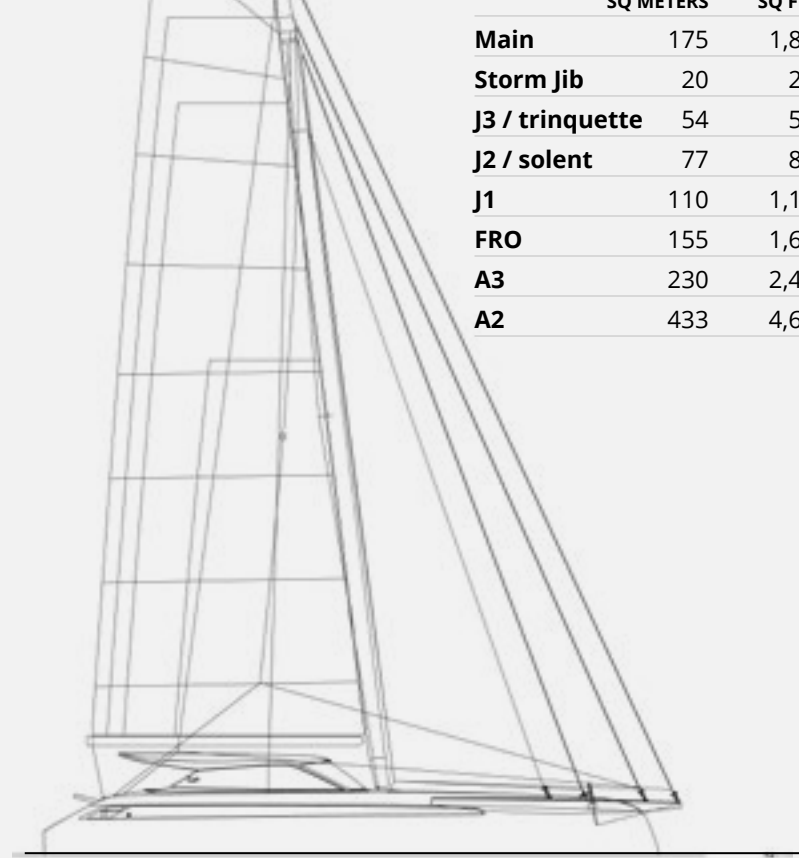

**REGATTA MAST**  
29M

	SQ METERS	SQ FEET
<b>Main</b>	175	1,884
<b>Storm Jib</b>	20	215
<b>J3 / trinquette</b>	54	581
<b>J2 / solent</b>	77	829
<b>J1</b>	110	1,184
<b>FRO</b>	155	1,668
<b>A3</b>	230	2,476
<b>A2</b>	433	4,660

## Specifications

	METRIC	IMPERIAL
<b>LOA</b>	20.75	68.00
<b>LWL</b>	20.75	68.00
<b>BOA</b>	9.10	29.90
<b>Draft Board Down</b>	3.76	9.84
<b>Draft Board Up</b>	1.20	3.90
<b>Mast Clearance</b>	27.50	90.20
<b>Mast Length</b>	25.00	82.00
<b>Displacement</b> (as per Standard Specifications)	17.800 kg	39.242 Lbs
<b>Displacement Max Load</b>	23.800 kg	54.470 Lbs
<b>Bridge Deck Clearance</b> (Mid load)	1.00	3.30
<b>Fuel Capacity</b>	2 x 378 L	2 x100 Gal
<b>Water Capacity</b>	2 x 378 L	2 x100 Gal





GUNBOAT 68

## You set the cursor

Defined by your sailing plans. From a full cruising program to mixing it up with the Gunboat family at regattas, your Gunboat 68 will be optimized to suit your sailing and adventures.»





GUNBOAT 68





GUNBOAT 68



## About Gunboat

**Gunboat began in 2002 to build comfortable, family-friendly, fast cruising catamarans that utilized the latest in race boat technology. At that time, the cruising catamaran market was composed of cruisers that typically weren't great performers. On the other end of the spectrum, the performance world had embraced multihulls, with one world record after another falling to maxi racing catamarans. The synthesis of cruising and high-performance multihulls was a revolution, and a new luxury performance market segment was born.**

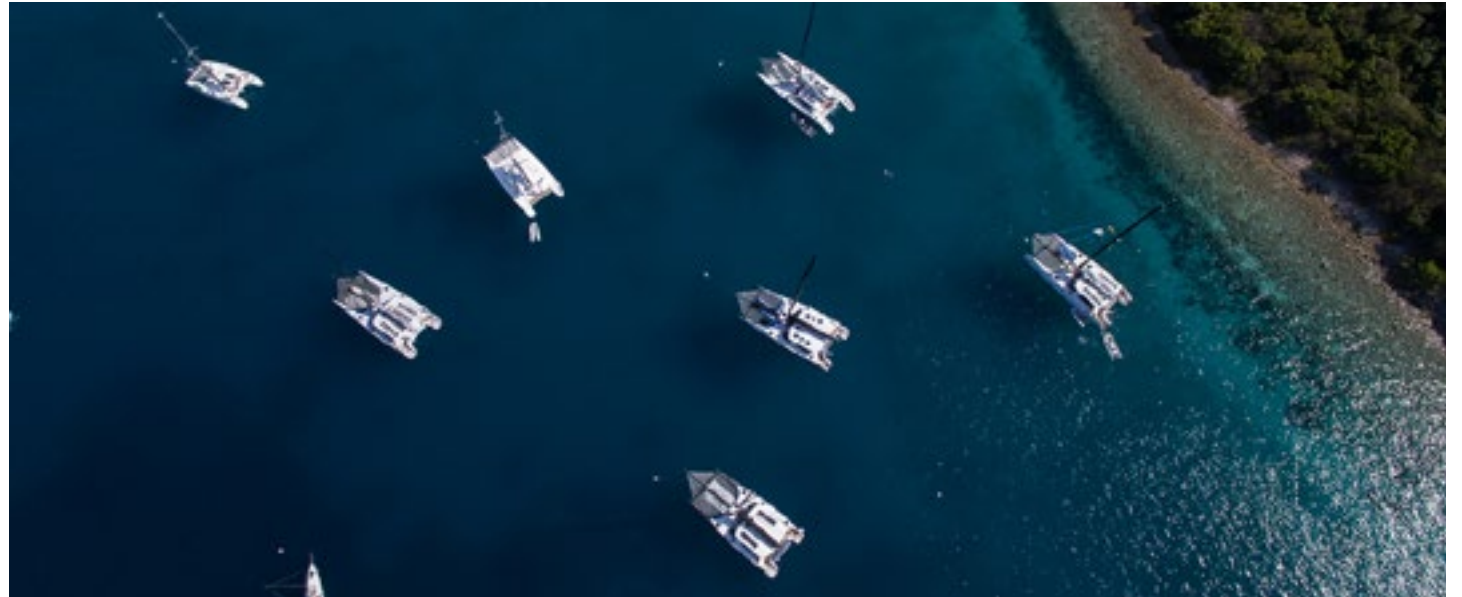

Through years of head-turning designs, enviable cruising speeds, and regatta performance, Gunboat established the gold standard for luxury performance catamarans - Grand Prix monohull performance, with the space, comfort, and volume of a cat, and the seaworthiness to handle the toughest blue water passages.

Under the ownership of Grand Large Yachting since 2016, Gunboat continues to innovate and lead the market. The all-new Gunboat 68 incorporates generations of owner experience and collaborative partnerships and delivers higher quality and more luxury along with the brag-worthy Gunboat performance. Now built by an expert team and with the sound financial backing of the GLY parent company, production is taking place in new state-of-the-art facilities in La Grande Motte, France; The US office

operates out of the Newport Shipyard, as Newport, RI (USA) represents the roots of the brand and the common summer port for nearly half of the Gunboats.

The exclusive fleet of over 30 Gunboats (spanning 48ft - 90ft) cruise and race in many parts of the world, a private but close-knit family of globe-trotting owners and crew who altogether have sailed over two million sea miles. The collective experience, knowledge gained from working with premier designers, and years of refinement and innovation push us to ever improve and evolve the market segment we created - which translates into great sailing and a lot of fun and adventure! We're passionate about the Gunboat experience and dedicated to providing ongoing support and Gunboat events for our growing community.



# Explore the Gunboat 68

## VIDEOS

- ▶ Sailing and Interior
- ▶ First Sea Trials
- ▶ Factory Launch, Gunboat 68 Splash

## REVIEWS AND TECHNICAL ARTICLES

- ☰ **Multihulls Magazine Review**  
Philippe Echelle, (Issue 194 April/May 2019)  
> contact sales@gunboat.com to request a copy
- ☰ **Technical Brief**  
Seahorse Magazine - (Feb 2018)

## GUNBOAT ARTICLE SERIES

- ☰ Exterior Design
- ☰ Internal Structure
- ☰ Daggerboards
- ☰ Interior
- ☰ Systems
- ☰ Steering
- ☰ Rigging
- ☰ Paint & Finishes
- ☰ Deck Gear
- ☰ Sail Plan

## GUNBOAT NEWS

- ☰ Gunboat 68 Condor Sea Trials
- ☰ Gunboat 68 Condor's Debut at the Races







GUNBOAT 68

[www.gunboat.com](http://www.gunboat.com)

[sales@gunboat.com](mailto:sales@gunboat.com)